

SECURE DIGITAL MEMORY CARD

TFLASH PUSH PUSH TYPE

Specifications:

Current Rating:0.5 Amp
 Voltage Rating:100V AC/DC
 Contact resistance:100m Ohm Max
 Insulator resistance:1,000M ohm min.
 Withstanding Voltage:500V AC/Minute
 Operating Temperature Range:-20°~+85° C

Material And Finish

Insulator:High Temperature Plastic(UL 94V-0)
 Contact:Copper Alloy
 Contact Plated:Selective Gold plated(standard)
 Shell:Stainless steel

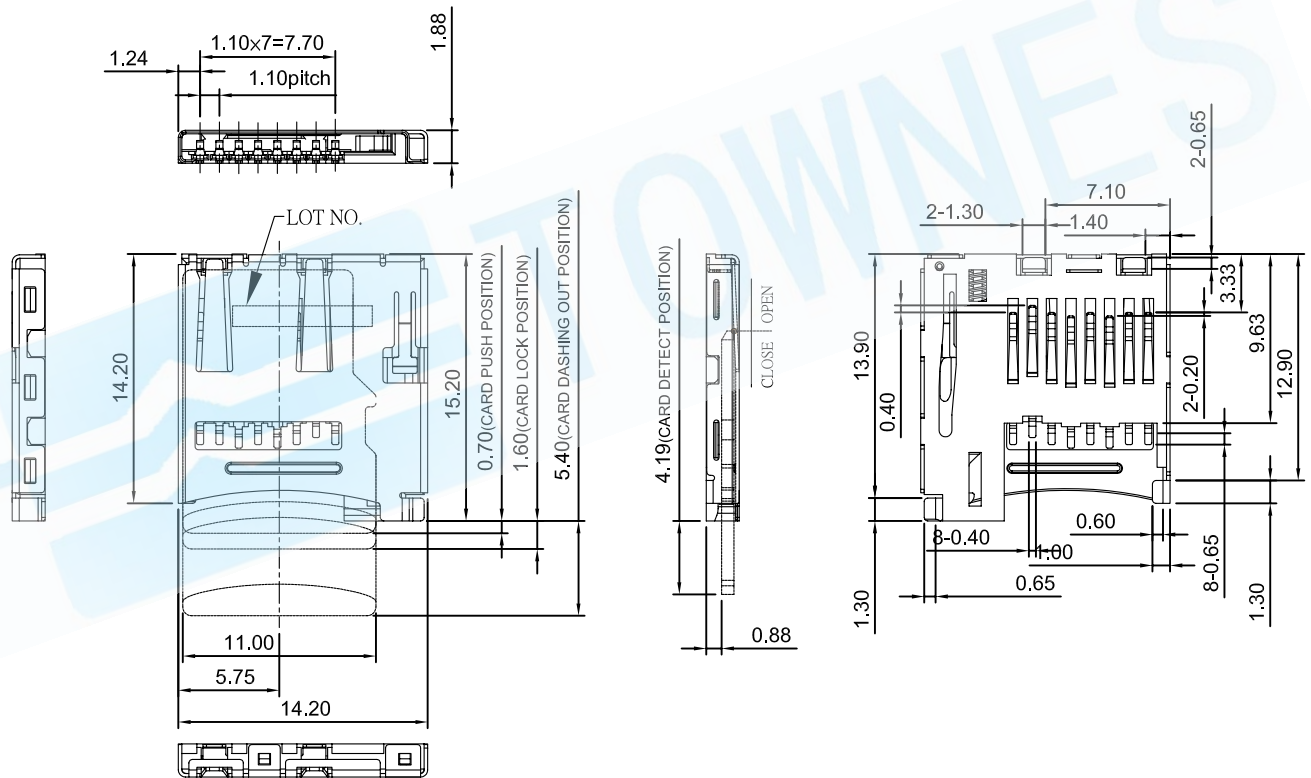
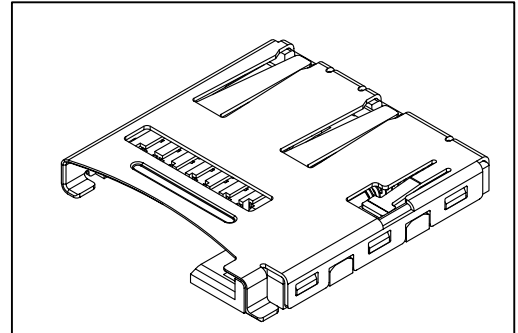

How To Order

TSD-08MXX-001

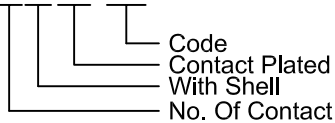

Contact Plated

Full Gold Type	Selective Plated Type Gold Plated on Contact Area Tin Plated on Solder Area	Full Tin Type
GF : Gold Flash	HF : Gold Flash, Tin 100u"	T1 : Tin 100u"
G1 : Gold 3u"	H1 : Gold 3u", Tin 100u"	T2 : Tin 200u"
G2 : Gold 5u"	H2 : Gold 5u", Tin 100u"	
G3 : Gold 10u"	H3 : Gold 10u", Tin 100u"	
G4 : Gold 15u"	H4 : Gold 15u", Tin 100u"	
G5 : Gold 20u"	H5 : Gold 20u", Tin 100u"	
G6 : Gold 30u"	H6 : Gold 30u", Tin 100u"	

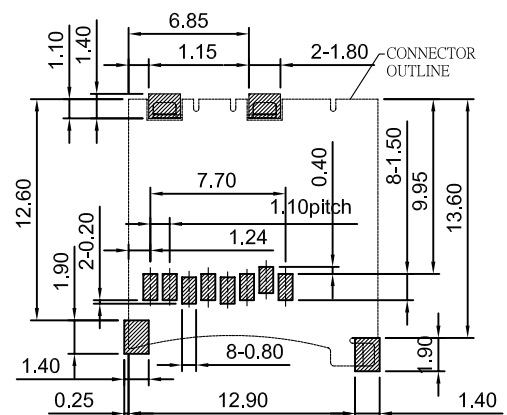

Recommended PCB Layout